



ES450 SERIES HIGH PERFORMANCE FREQUENCY INVERTER INSTRUCTION MANUAL

Version 1.0



Copyright © 2025 JAARIS Automation PVT. Ltd. All Rights Reserved.

The information in this document is subject to change without prior notice. No part of this document may be reproduced, stored in a retrieval system, or transmitted in any form or by any means (electronic, mechanical, photocopying, recording, or otherwise) without prior written permission from JAARIS Automation PVT. Ltd.

FOREWORD

Thank you for choosing the **ES450 Series Frequency Inverter**.

The **ES450 Series**, independently developed by our company, is a high-performance universal vector control inverter, offering superior quality, multiple functions, and low noise operation.

This **User Manual** provides detailed information on the dimensions, function parameter settings, and proper usage of the **ES450 Series Frequency Inverter**. Please read this manual carefully before installation and operation to ensure optimal performance and safety.

NAMEPLATE

Model: ES450-0R75G-S2

Max Appli Motor: 0.75kW

Input: AC1PH 200-240V 50/60Hz 8.2A

Output: AC3PH 0-240V 0-400Hz 4.0A

Operating Temperature: 10 ~ 50° C



MODEL

Three Phase 380VAC Input, Three Phase 380VAC Output

MODEL	POWER (KW)	OUTPUT CURRENT (A)
ES450 -T3-0R7	0.75	3
ES450 -T3-0R7	1.5	4
ES450 -T3-2R2	2.2	5

Single Phase 220VAC Input, Three Phase 220VAC Output

MODEL	POWER (KW)	OUTPUT CURRENT (A)
ES450-S2-0R4	0.4	2.5
ES450-S2-0R7	0.75	5
ES450-S2-1R5	1.5	7
ES450-S2-2R2	2.2	10

DIMENSIONS

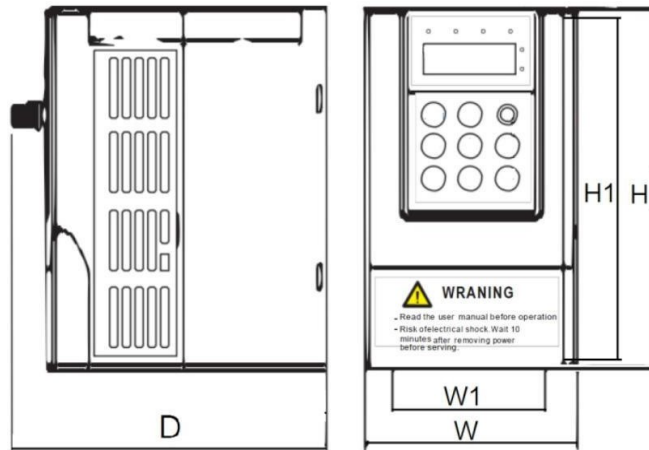

MODEL	W (MM)	W1 (MM)	H (MM)	H1 (MM)	D (MM)	D1 (MM)	APERTURE (MM)
ES450-S2-OR4	85	74	141.5	130.5	113	10	4
ES450-S2-OR7	85	74	141.5	130.5	113	10	
ES450-S2-1R5	85	74	141.5	130.5	113	10	
ES450-S2-2R2	100	89	151	140	116.5	10.5	
ES450-S2-OR7							
ES450-S2-1R5							
ES450-S2-2R2							

OPERATING KEYBOARD INSTRUCTIONS

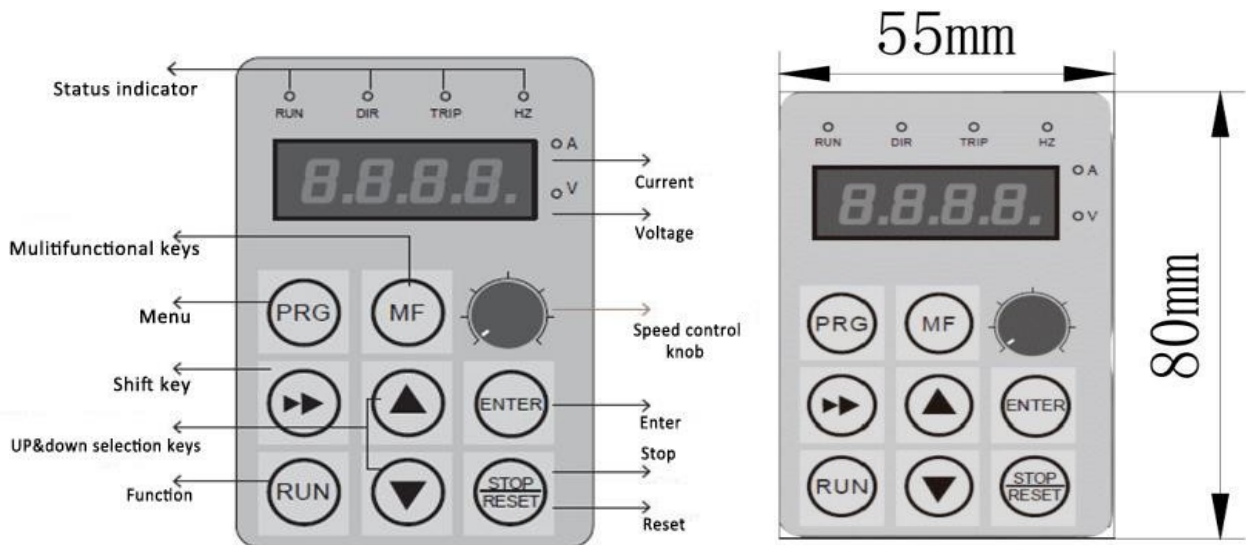

WIRING INSTRUCTIONS

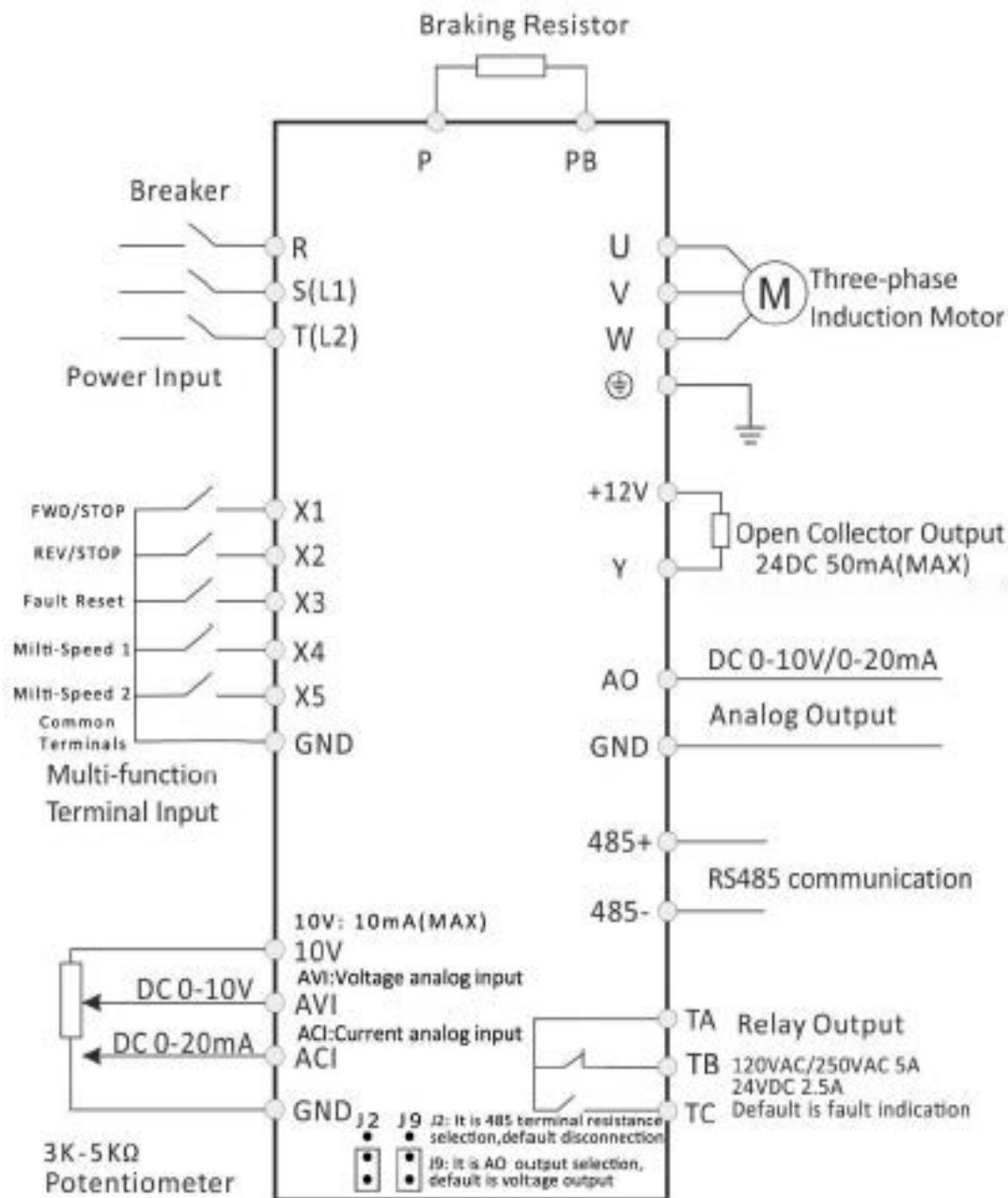

Description of Control Circuit Terminal Function

Code of terminal	Terminal	Function
GND	Public terminal of the control circuit	
10V	10V output voltage	Commonly used as working voltage of the external potentiometer Maximum current:10mA
12V	24V output voltage	Commonly used as working voltage of the logic input terminal Maximum current:10mA
AVI	Voltage Analog input	Analog voltage input:0 ~ +10 V Set according to parameter F2.00~F2.03
ACI	Current Analog input	Analog voltage input:0/4~ 20mA Set according to parameter F2.04~F2.07
X1	Digital input X1	Set according to parameter F2.13, and factory set defaults to be FWD.
X2	Digital input X2	Set according to parameter F2.14, and factory set defaults to be REV.
X3	Digital input X3	Set according to parameter F2.15, and factory set defaults to be IDLE.
X4	Digital input X4	Set according to parameter F2.16, and factory set defaults to be IDLE.
X5	Digital input X5	Set according to parameter F2.17, and factory set defaults to be Pulse Frequency Input.
TA-TB-TC	Relay output	Set according to parameter F2.20 Contact rating: AC 250V/5A DC 24V/2.5A
Y1	Open-collector output	Default running indication
AO	Analog output	Analog voltage input:0 ~ +10 V Analog voltage input:0/4~ 20mA Set according to parameter F2.10~F2.12

Description of Main Circuit Terminals

Code of terminal	Terminal	Function
R	Power input for main circuit	R/S/T 3-Phase, AC power input terminal, 380V, 50Hz/60Hz L1/L2 220V Model connect terminals
S/L1		
T/L2		
U	Output of frequency inverter	Terminal for connection to motor
V		
W		
P	Connection of braking resistor	Terminal for connection to braking resistor
PB		
	Grounding	Terminal for grounding
		400V level: grounding resistance is 4Ω or below.

PARAMETER DESCRIPTION

○—Parameters that can be modified in any state .

× - Parameters that cannot be modified in the running state.

◆—The actual detection parameters cannot be modified.

◇—The manufacturer parameters are limited to the manufacturer and are prohibited from being modified by the user.

P0 group - Basic run parameters					
Code	Description	Contents	Predetermined area	Factory setting	Change
P0.00	Frequency inverter power specification	Display current power	0.10~99.99KW	Model setting	◆
P0.01	Master controller software version	Display current software version number	1.00~99.99	1.00	◆
P0.02	Run command channel selection	0: panel run command channel	0~2	0	○
		1: terminal running command channel			
		2: Communication running command channel			
P0.03	Frequency given selection	0: panel potentiometer	0~7	0	○
		1: Digital reference 1, operation panel ▲, ▼ key adjustment			
		2: Digital reference 2, terminal UP / DOWN adjustment			
		3: AVI simulation given (0 ~ 10V)			
		4: Combination given			
		5: ACI given (0 ~ 20mA)			
		6: Communication given			
		7: Pulse given			
Note: Select combination to give timing, and the combination given mode is selected in P1.15.					
P0.04	Maximum output frequency	The maximum output frequency is the highest frequency allowed by the frequency inverter and is the reference for the acceleration/deceleration setting.	MAX {50.0, 【P0.05】 } ~ 999.9Hz	50.0Hz	×

Code	Description	Contents	Predetermined area	Factory setting	Change
P0.05	Upper limit frequency	The operating frequency cannot exceed this frequency	MAX{0.1, 【P0.06】 } ~ 【P0.04】	50.0Hz	×
P0.06	Lower limit frequency	The operating frequency cannot be lower than the frequency	0.0 to upper limit frequency	0.0Hz	×
P0.07	Lower limit frequency arrival processing	0: zero speed operation	0~2	0	×
		1: Run at the lower limit frequency			
		2: Downtime			
P0.08	Running frequency digital setting	The set value is the frequency number given initial value	0.0 to upper limit frequency	10.0Hz	○
P0.09	Digital frequency control	LED ones place: power down storage	0000~2111	0000	○
		0: storage			
		1: not stored			
		LED ten: stop to keep			
		0: keep			
		1: don't keep			
		LED Hundreds: UP/DOWN Negative Frequency Adjustment			
		0: invalid			
		1: valid			
		LED Thousands: PID, PLC frequency superposition selection			
		0: invalid			
1:P0.03+PID					
P0.10	acceleration time	Time required for the frequency inverter to accelerate from zero frequency to the maximum output frequency	0.1~255.0S 0.4~4.0KW 7.5S	Model setting	○
P0.11	deceleration time	Time required for the frequency inverter to decelerate from the maximum output frequency to zero frequency	5.5~22KW 15.0S		
P0.12	Running direction setting	0: forward	0~2	0	○
		1: reverse			
		2: Reverse rotation is prohibited			
P0.13	V/F curve setting	0: linear curve	0~2	0	×
		1: square curve			
		2: Multi-point VF curve			

Code	Description	Contents	Predetermined area	Factory setting	Change
P0.14	Torque boost	Vector Control: Set this parameter to 0.0	0.0~30.0%	Model setting	○
		VF control: This parameter is the manual torque boost amount;			
		This value is set relative to the motor's rated voltage.			
P0.15	Torque boost cutoff frequency	This setting is the boost cutoff frequency point when the manual torque is boosted.	0.0~50.0Hz	15.0Hz	×
P0.16	Carrier frequency setting	For occasions that require silent operation, the carrier frequency can be appropriately increased to meet the requirements, but increasing the carrier frequency will increase the heat generation of the frequency inverter.	2.0~16.0KHz 0.4~3.0KW 4.0KHz 4.0~7.5KW 3.0KHz	Model setting	×
P0.17	V/F frequency value F1		0.1 to frequency value F2	12.5Hz	×
P0.18	V/F voltage value V1		0.0 to voltage value V2	25.00 %	×
P0.19	V/F frequency value F2		Frequency value F1 to frequency value F3	25.0Hz	×
P0.20	V/F voltage value V2		Voltage value V1 ~ voltage value V3	50.00 %	×
P0.21	V/F frequency value F3		Frequency value F2 ~ motor rated frequency [P4.03]	37.5Hz	×
P0.23	user password		Set any non-zero number and wait for 3 minutes or power down to take effect.	0~9999	0

P1 group - auxiliary operating parameters					
Code	Description	Contents	Predetermined area	Factory setting	Change
P1.00	Starting method	LED ones: start mode 0: start from start frequency	0000~0011	00	×
		1: First DC braking and then starting from the starting frequency			
		LED ten: power outage or abnormal restart mode			
		0: invalid			
		1: Starting from the starting frequency			
		LED Hundreds: Reserved			
LED Thousands: Reserved					
P1.01	Starting frequency		0.0~50.0Hz	1.0Hz	○
P1.02	Starting DC braking voltage		0.0~50.0%× rated motor voltage	0.00%	○
P1.03	Starting DC braking time		0.0~30.0s	0.0s	○
P1.04	Stop mode	0: deceleration stop	0~1	0	×
		1: Free stop			
P1.05	Stop DC braking start frequency		0.0 to upper limit frequency	0.0Hz	○
P1.06	Shutdown DC braking voltage		0.0~50.0%×rated motor voltage	0.00%	○
P1.07	DC braking time at stop		0.0~30.0s	0.0s	×
P1.08	DC brake waiting time		0.00~99.99s	0.00s	×
P1.09	Forward jog frequency setting	Set the jog positive and negative frequency	0.0~50.0Hz	10.0Hz	○
P1.10	Reverse jog frequency setting				

Code	Description	Contents	Predetermined Area	Factory setting	Change
P1.11	Jog acceleration	Set jog acceleration/deceleration time	0.1 ~999.9S 0.4 ~4.0KW 5.5 ~7.5KW 10.0S 15.0S	Model setting	○
P1.12	Jog deceleration				
P1.13	Jump frequency	By setting the skip frequency and range, the frequency inverter can be avoided from the mechanical resonance point of the load.	0.0 to upper limit frequency	0.0Hz	○
P1.14	Jump range		0.0~10.0Hz	0.0Hz	○
P1.15	Frequency combination given mode	0: potentiometer + digital frequency 1	0~7	0	×
		1: potentiometer + digital frequency 2			
		2: Potentiometer + AVI			
		3: Digital frequency 1+AVI			
		4: Digital frequency 2+AVI			
		5: Digital frequency 1 + multi-speed			
6: Digital frequency 2+multi-speed					
P1.16	Programmable operation control (simple PLC operation)	1): LED units digits: operating mode selection 0: invalid 1: valid 2): LED ten digits: operating mode 0: single cycle 1: continuous cycle selection 2: Keep the final value after single cycle LED Hundreds: Start mode 0: Restart from the first segment 1: Start from the phase of the stop (fault) time 2: Start from the stage and frequency of the stop (fault) time LED Thousands: Power-down storage option 0: No storage 1: Storage	0000~1221	0000	×
P1.17	Multi-speed frequency 1	Set the segment speed 1 frequency	- upper limit frequency ~ upper limit frequency	5.0Hz	○
P1.18	Multi-speed frequency 2	Set the segment speed 2 frequency	- upper limit frequency ~ upper limit frequency	10.0Hz	○
P1.19	Multi-speed frequency 3	Set the segment speed 3 frequency	- upper limit frequency ~ upper limit frequency	15.0HZ	○
P1.20	Multi-speed frequency 4	Set the segment speed 4 frequency	- upper limit frequency ~ upper limit frequency	20.0HZ	○
P1.21	Multi-speed frequency 5	Set the segment speed 5 frequency	- upper limit frequency ~ upper limit frequency	25.0HZ	○
P1.22	Multi-speed frequency 6	Set the segment speed 6 frequency	- upper limit frequency ~ upper limit frequency	37.5HZ	○
P1.23	Multi-speed frequency 7	Set the segment speed 6 frequency	- upper limit frequency ~ upper limit frequency	50.0HZ	○

Code	Description	Contents	Predetermined area	Factory setting	Change
P1.24	Phase 1 run time	Set the segment speed 2 running time (the unit is selected by [P1.35], the default is seconds)	0.0~999.9s	10.0s	○
P1.25	Phase 2 run time	Set the segment speed 2 running time (the unit is selected by [P1.35], the default is seconds)	0.0~999.9s	10.0s	○
P1.26	Phase 3 run time	Set the segment speed 3 running time (the unit is selected by [P1.35], the default is seconds)	0.0~999.9s	10.0s	○
P1.27	Phase 4 run time	Set the segment speed 4 running time (the unit is selected by [P1.35], the default is seconds)	0.0~999.9s	10.0s	○
P1.28	Phase 5 run time	Set the segment speed 5 running time (the unit is selected by [P1.35], the default is seconds)	0.0~999.9s	10.0s	○
P1.29	Phase 6 run time	Set the segment speed 6 running time (the unit is selected by [P1.35], the default is seconds)	0.0~999.9s	10.0s	○
P1.30	Phase 7 run time	Set the segment speed 7 running time (the unit is selected by [P1.35], the default is seconds)	0.0~999.9s	10.0s	○
P1.31	Stage acceleration and deceleration time selection 1	LED ones: Phase 1 acceleration and deceleration time 0~1	0000~1111	0000	○
		LED ten: phase 2 acceleration and deceleration time 0~1			
		LED Hundreds: Stage3 Acceleration/Deceleration Time 0~1			
		LED Thousand: Stage 4 Acceleration/Deceleration Time 0~1			
P1.32	Stage acceleration and deceleration time selection 1	LED ones: Stage 5 acceleration and deceleration time 0~1	000~111	000	○
		LED ten: phase 6 acceleration and deceleration time 0~1			
		LED Hundreds: Stage7 Acceleration/Deceleration Time 0~1			
		LED Thousands: Reserved			
P1.33	Acceleration time 2	Set the acceleration/deceleration time 2	0.1~999.9s 0.4~4.0KW 10.0s 5.5~7.5KW 15.0s	10.0s	○
P1.34	Deceleration time 2				
P1.35	Time unit selection	LED ones place: process PID time unit	000~211	000	×
		LED ten: simple PLC time unit			
		LED Hundreds: Conventional acceleration and deceleration time unit			
		LED Thousands: Reserved			
		0: The unit is 1 second.			
		1: the unit is 1 point			
1: unit is 0.1 second					

P2 group - analog and digital input and output parameters					
Code	Description	Contents	Predetermined area	Factory setting	Change
P2.00	AVI input lower limit voltage	Set AVI upper and lower voltage	0.00~ 【P2.01	0.00V	○
P2.01	AVI input upper limit voltage		【P2.01】 ~ 10.00V	10.00V	○
P2.02	AVI lower limit correspondin	Set the AVI upper and lower limit corresponding setting, which corresponds to the percentage of the upper limit frequency [P0.05].	- 100.0% ~ 100.0%	0.0%	○
P2.03	AVI upper limit correspondin			100.00 %	○
P2.04	ACI input lower limit current	Set the ACI input upper and lower limit current	0.00~ 【P2.05】	0.00m A	○
P2.05	ACI input upper limit current		【P2.04】 ~ 20.00mA	20.00m A	○
P2.06	ACI lower limit correspondin	Set the upper and lower limits of the ACI, which corresponds to the percentage of the upper limit frequency [P0.05].	- 100.0% ~ 100.0%	0.0%	○
P2.07	ACI upper limit correspondin			100.00 %	○
P2.08	Analog input signal filtering time constant	This parameter is used to filter the AVI, ACI, and panel potentiometer input signals to eliminate the effects of interference.	0.1~5.0s	0.1s	○
P2.09	Analog input anti-shake deviation limit	When the analog input signal fluctuates frequently around a given value, the frequency fluctuation caused by this fluctuation can be suppressed by setting P2.09.	0.00~0.10V	0.00V	○
P2.10	AO analog output terminal function	1: Output current	0~5	0	○
		2: Motor speed			
		3: output voltage			
		4: AVI			
		5: ACI			

Code	Description	Contents	Predetermined area	Factory setting	Change
P2.11	AO output lowerlimit	Set the upper and lower limits of the AO output	0.00~10.00V/	0.00V	○
P2.12	AO output upper limit		0.00~20.00mA	10.00V	○
P2.13	Input terminal X1 function	0: Control terminal idle	0~27	3	✕
		1: Forward jogcontrol			
		2: Reverse jog control			
		3: Forward Control (FWD)			
		4: Reverse Control (REV)			
5: Three-line operation control					
P2.14	Input terminal X2 function	6: Free stop control	0~27	4	✕
		7: External stop signal input (STOP)			
		8: External reset signal input (RST)			
		9: External fault normally open input			
P2.15	Input terminal X3 function	10: Frequency increment command (UP)	0~27	0	✕
		11: Frequency decrement instruction (DOWN)			
		12: Reserve			
		13: Multi-speed selection S1			
		14: Multi-speed selection S2			
15: Multi-speed selection S3					
P2.16	Input terminal X4 function	16: Run command channel forced to terminal	0~27	0	✕
		17: Run command channel forced communication			
		18: Stop DC braking command			
		19: Frequency switched to AVI			
		20: Frequency is switched to digital frequency1			
21: Frequency switching to digital frequency2					
P2.17	Input terminal X5 function	22: Pulse frequency input (only valid for X5)	0~27	22	✕
		23: Counter clear signal			
		24: Counter trigger signal			
		25: Timer clear signal			
		26: Timer trigger signal			
27: Acceleration and deceleration time selection					
P2.18	FWD/REV controlmode	0: Two-wire control mode 1	0~3	0	✕
		1: Two-wire control mode 2			
		2: Three-wire control mode 1			
		3: Three-wire control mode 2			

Code	Description	Contents	Predetermined area	Factory setting	Change
P2.19	Terminal function detection selection at power-on	0: The terminal running command is invalid at power-on.	0~1	0	✕
		1: The terminal running command is valid at power-on.			
P2.20	Relay output setting	0: idle	0~14	5	○
		1: The frequency inverter is ready for operation			
P2.21	Reserved 0	2: The frequency inverter is running	—	0	◆
		3: The frequency inverter runs at zero speed			
		4: External downtime			
		5: frequency inverter failure			
		6: Frequency/speed arrival signal (FAR)			
		7: Frequency/speed level detection signal (FDT)			
		8: Output frequency reaches the upper limit			
		9: Output frequency reaches the lower limit			
		10: frequency inverter overload pre-alarm			
		11: Timer overflow signal			
		12: Counter detection signal			
		13: Counter reset signal			
		14: Auxiliary motor			
		15: Forward run			
16: Reverse run					
P2.22	Closing delay	The delay of the relay R state changes to the output	0.0~255.0s	0.0s	✕
P2.23	Disconnection delay				
P2.24	Frequency reaches the FAR detection range	The output frequency is within the positive and negative detection width of the set frequency and the terminal outputs a valid signal (low level).	0.0Hz ~ 15.0Hz	5.0Hz	○
P2.25	FDT level setting		0.0Hz to upper limit frequency	10.0Hz	○
P2.26	FDT hysteresis value		0.0~30.0Hz	1.0Hz	○
P2.27	UP/DOWN terminal modification rate	The function code is the frequency modification rate when the UP/DOWN terminal setting frequency is set, that is, the UP/DOWN terminal is shorted to the COM terminal for one second, and the frequency is changed.	0.1Hz~ 99.9Hz/s	1.0Hz/s	○

Code	Description	Contents	Predetermined area	Factory setting	Change
P2.28	Input terminal pulse trigger mode setting (X1 ~ X5)	0: indicates the level trigger mode	0~1FH	0	○
		1: indicates the pulse trigger mode			
P2.29	Input terminal effective logic setting (X1 ~ X5)	0: indicates positive logic, that is, the Mi terminal is connected to the common terminal, and the disconnection is invalid.	0~1FH	0	○
		1: indicates the inverse logic, that is, the connection between the Mi terminal and the common terminal is invalid, and the disconnection is effective.			
P2.30	X1 filter coefficient	Used to set the sensitivity of the input terminal. If the digital input terminal is susceptible to interference and cause malfunction, increase this parameter to increase the anti-interference ability, but if the setting is too large, the sensitivity of the input terminal will decrease.	0~9999	5	○
P2.31	X2 filter coefficient		0~9999	5	○
P2.32	X3 filter coefficient		0~9999	5	○
P2.33	X4 filter coefficient		0~9999	5	○
P2.34	X5 filter coefficient		1: represents the 2MS scan time unit	0~9999	5

P3 group - PID parameters					
Code	Description	Contents	Predetermined area	Factory setting	Change
P3.00	PID function setting	LED ones place: PID adjustment characteristics	0000~2122	1010	×
		0: invalid			
		1: Positive effect			
		When the feedback signal is greater than the given amount of PID, the frequency inverter output frequency is required to decrease (ie, the feedback signal is reduced).			
		2: Negative effect			
		When the feedback signal is greater than the given amount of PID, the frequency inverter output frequency is required to rise (ie, the feedback signal is reduced).			
		LED ten: PID given input channel			
		0: keyboard potentiometer			
		The PID given amount is given by the potentiometer on the operator panel.			
		1: Digital given			
		The PID given amount is given by the number and is set by the function code P3.01.			
2: Pressure given (MPa, Kg)					
P3.00	PID function setting	LED Hundreds: PID feedback input channel	0000~2122	1010	×
		0: AVI			
		1: ACI			
		LED Thousands: PID Sleep Selection			
		0: invalid			
		1: normal sleep			
		In this mode, specific parameters such as P3.10~P3.13 need to be set.			
		2: Disturbing sleep			
The parameter setting is the same as when the sleep mode is selected as 0. If the PID feedback value is within the range of the P3.14 set value, the sleep delay time is maintained and the disturbance sleep is entered. When the feedback value is less than the wake threshold (the PID polarity is positive), it will wake up immediately					

Code	Description	Contents	Predetermined area	Factory setting	Change
P3.01	Setting a quantitative number	Use the operation keyboard to set the PID control's given amount. This function is valid only when the PID reference channel selects the digital reference (P3.00 tens is 1 or 2). If the P3.00 tens place is 2, it is used as the pressure reference, and this parameter is consistent with the unit of P3.18.	0.0~100.0%	0.00%	○
P3.02	Feedback channel gain	When the feedback channel is inconsistent with the set channel level, this function can be used to adjust the gain of the feedback channel signal.	0.01~10.00	1.00	○
P3.03	Proportional gain P	The speed of the PID adjustment speed is set by the two parameters of proportional gain and integration time. It is required to increase the proportional gain and reduce the integration time. It is required to reduce the proportional gain and increase the integration time. In general, the derivative time is not set.	0.01~5.00	2.00	○
P3.04	Integration time Ti		0.1~50.0s	1.0S	○
P3.05	Derivative time Td		0.1~10.0s	0.0s	○
P3.06	Sampling period T	The larger the sampling period is, the slower the response is, but the better the suppression of the interference signal is, and it is not necessary to set it normally.	0.1~10.0s	0.0s	○
P3.07	Deviation limit	The deviation limit is the ratio of the absolute value of the deviation between the system feedback amount and the given amount to the given amount. When the feedback amount is within the deviation limit range, the PID adjustment does not work.	0.0~20.0%	0.0%	○
P3.08	Closed loop preset frequency	Frequency and running time of the frequency inverter before the PID is put into operation	0.0 to upper limit frequency	0.0Hz	○
P3.09	Preset frequency hold time		0.0~999.9s	0.0s	×
P3.10	Wake-up threshold	If the actual feedback value is greater than the set value, and the frequency output by the frequency inverter reaches the lower limit frequency, the frequency inverter enters the sleep state (ie, zero speed running) after the delay waiting time defined by P3.12; The percentage of the PID setpoint.	0.0~150.0%	100.0%	○

Code	Description	Contents	Predetermined area	Factory setting	Change
P3.11	Wake threshold coefficient	If the actual feedback value is less than the set value, the frequency inverter will go out of sleep and start working after the delay waiting time defined by P3.13; this value is the percentage of the PID set value.	0.0~150.0%	90.0%	○
P3.12	Sleep delay time	Set sleep delay time	0.0~999.9s	100.0s	○
P3.13	Awakening delay time	Set wakeup delay time	0.0~999.9s	1.0s	○
P3.15	Burst detection delay time	Set the squib detection delay time	0.0~130.0s	30.0S	○
P3.16	High pressure detection threshold	When the feedback pressure is greater than or equal to this set value, the explosion alarm "EPA0" is reported after the P3.15 bursting delay, and the explosion alarm "EPA0" is automatically reset when the feedback pressure is less than this set value; the threshold is given The percentage of constant pressure.	0.0~200.0%	150.0 %	○
P3.17	Low pressure detection threshold	When the feedback pressure is less than this set value, the explosion alarm "EPA0" is reported after the P3.15 bursting delay, and the explosion alarm "EPA0" is automatically reset when the feedback pressure is greater than or equal to this set value; the threshold is given The percentage of constant pressure.	0.0~200.0%	50.0%	○
P3.18	Sensor range	Set the maximum range of the sensor	0.00~99.99 (MPa、 Kg)	10.00M Pa	○

P4 group - advanced function parameters					
Code	Description	Contents	Predetermined area	Factory setting	Change
P4.00	Motor rated voltage	Motor parameter setting	0~500V : 380V	Model setting	×
			0~250V : 220V		
P4.01	Motor rated current		0.1~999.9A	Model setting	×
P4.02	Motor rated speed		0~ 60000Krpm	Model setting	×
P4.03	Motor rated frequency		1.0~999.9Hz	50.0Hz	×
P4.04	Motor stator resistance	Set the motor stator resistance	0.001~ 20.000Ω	Model setting	○
P4.05	Motor no-load current	Set the motor no-load current	0.1~ 【P4.01	Model setting	×
P4.06	AVR function	0: invalid	0~2	0	×
		1: Full effective			
		2: invalid only when decelerating			
P4.07	Cooling fan control	0: automatic control mode	0~1	0	○
		1: The power-on process keeps running			
P4.08	Number of automatic resets	When the number of fault resets is set to 0, there is no automatic reset function, only manual reset, 10 means that the number of times is not limited, that is, countless times.	0~10	0	×
P4.09	Fault auto reset interval	Set the fault auto reset interval	0.5~25.0s	3.0s	×
P4.10	Energy consumption braking starting voltage	If the internal DC side voltage of the frequency inverter is higher than the energy consumption braking start voltage, the built-in braking unit operates. If a braking resistor is connected at this time, the voltage of the internal voltage of the frequency inverter will be released through the braking resistor, so that the DC voltage will fall back.	330~ 380/660~ 800V	350/780 V	○
P4.11	Energy consumption braking action ratio		10~100%	100%	○

P5 group - protection function parameters					
Code	Description	Contents	Predetermined area	Factory setting	Change
P5.00	Protection settings	LED ones: motor overload protection option	0000~1211	0001	×
		0: invalid 1: valid			
		LED ten: PID feedback disconnection protection			
		0: invalid 1: Protect action and free stop			
		LED Hundreds: Reserved			
		LED Thousands: Oscillation suppression option			
		0: invalid 1: valid			
P5.02	Undervoltage protection level	This function code specifies the lower limit voltage allowed by the DC bus when the frequency inverter is working normally.	50~280/50~480V	180/360V	×
P5.03	Deceleration voltage limiting factor	This parameter is used to adjust the ability of the drive to suppress overvoltage during deceleration.	0: off, 1 to 255	1	×
P5.04	Overpressure limit level	The overvoltage limit level defines the operating voltage for overvoltage stall protection	350~400/660~850V	375/790V	×
P5.05	Acceleration current limit	This parameter is used to adjust the ability of the drive to suppress overcurrent during acceleration.	0: off, 1 to 99	10	×
P5.06	Constant speed current limiting factor	This parameter is used to adjust the ability of the drive to suppress overcurrent during constant speed.	0: off, 1 to 10	0	×
P5.07	Current limit level	The current limit level defines the current threshold for the automatic current limit action, the set value is a percentage of the rated current of the drive.	50%~250%	180%	×
P5.08	Feedback disconnection detection value	The value is the percentage given by the PID. When the feedback value of the PID continues to be less than the feedback disconnection detection value, the frequency inverter will make the corresponding protection action according to the setting of P5.00. It is invalid when P5.08=0.0%.	0.0~100.0%	0.0%	×
P5.09	Feedback disconnection detection	After the feedback disconnection occurs, the delay time before the action is protected.	0.1~999.9S	10.0s	×

Code	Description	Contents	Predetermined area	Factory setting	Change
P5.10	Frequency inverter overload pre-alarm level	The current threshold of the frequency inverter overload pre-alarm action, the set value is relative to the rated current of the frequency inverter.	0~150%	120%	○
P5.11	Frequency inverter overload pre-alarm delay	The output current of the frequency inverter is continuously longer than the overload pre-alarm level (P5.10), and the delay time between the output overload pre-alarm signals.	0.0~15.0s	5.0s	×
P5.12	Jog priority enable	0: invalid	0~1	0	×
P5.13	Oscillation suppression coefficient	When the motor is oscillating, set P5.00 thousand effective, turn on the oscillation suppression function, and then adjust by setting the oscillation suppression coefficient. Under normal circumstances, the oscillation amplitude is large, and the oscillation suppression coefficient P5.13, P5.14~P5.16 is increased. 16 does not need to be set; if it encounters special occasions, it needs to be used together with P5.13~P5.16.	0~200	30	○
P5.14	Amplitude suppression coefficient		0~12	5	○
P5.15	Oscillation suppression lower limit frequency		0.0~ 【P5.16】	5.0Hz	○
P5.16	Oscillation suppression upper limit frequency		【P5.15】 ~ 【P0.05】	45.0Hz	○
P5.17	Wave-by-wave current limit selection		LED unit position: selection in acceleration 0: invalid 1: valid LED ten: selection in deceleration 0: invalid 1: valid LED Hundreds: Select from constant speed 0: invalid 1: valid LED thousand: reserved	000~111	011

P6 group - communication parameters					
Code	Description	Contents	Predetermined area	Factory setting	Change
P6.00	Local address	Set the local address, 0 is the broadcast address.	0 ~ 247	1	×
P6.01	MODBUS communication configuration	LED ones place: baud rate selection	0000 ~ 0322	0000	×
		0:9600BPS			
		1:19200BPS			
		2:38400BPS			
		LED ten: data format			
		0: no parity			
		1: even parity			
		2: odd parity			
		LED Hundreds: Communication Response			
		0: normal response			
		1: only respond to the slave address			
		2: Not responding			
		3: Slave does not respond to the free stop command of the host in broadcast mode			
LED Thousands: Reserved					
P6.02	Communication timeout checkout time	If the unit does not receive the correct data signal within the time interval defined by this function code, then the unit thinks that the communication has failed, and the frequency inverter will decide whether to protect or maintain the current operation according to the setting of the communication failure action mode; When the value is set to 0.0, no RS485 communication timeout is detected.	0.1 ~ 100.0s	10.0s	×
P6.03	Local response delay	This function code defines the intermediate time interval between the end of the data frame reception of the frequency inverter and the transmission of the response data frame to the host computer. If the response time is less than the system processing time, the system processing time is subject to change.	0 ~ 200ms	5ms	×
P6.04	Proportional linkage coefficient	This function code is used to set the weight coefficient of the frequency inverter as the frequency command received by the slave through the RS485 interface. The actual running frequency of the machine is equal to the value of this function multiplied by the frequency setting command value received through the RS485 interface. In the linkage control, this function code can set the ratio of the running frequency of multiple frequency inverters.	0.01 ~ 10.00	1.00	○

P7 group - supplementary function parameters					
Code	Description	Contents	Predetermined area	Factory setting	Change
P7.00	Counting and timing mode	LED ones: count arrival processing	000~303	103	×
		0: Single cycle count, stop output			
		1: Single cycle count, continue output			
		2: Loop count, stop output			
		3: loop count, continue to output			
		LED ten: reserved			
		LED Hundreds: Timing Arrival Processing			
		0: One-week timing, stop output			
		1: Single-cycle timing, continue output			
		2: Cycle timing, stop output			
		3: Cycle timing, continue output			
	LED Thousands: Reserved				
P7.01	Counter reset value setting	Set the counter reset value	【P7.02】 ~ 9999	1	○
P7.02	Counter detection value setting	Set the counter detection value	0 ~ 【P7.01】	1	○
P7.03	Timing time setting	Set timing time	0~9999s	0s	○
P7.04	External pulse X5 input lower limit frequency	Set external pulse M5 input upper and lower limit frequency	0.00~ 【P7.14】	0.00KHz	○
P7.05	External pulse X5 input upper limit frequency		【P7.13】 ~ 99.99KHz	20.00 KHz	○
P7.06	External pulse X5 lower limit corresponding setting		-100.0%~ 100.0%	0.0%	○
P7.07	External pulse X5 upper limit corresponding setting	Set the upper and lower limits of the external pulse M5. This setting is relative to the maximum output frequency.	-100.0%~ 100.0%	100.00 %	○

P8 group - management and display parameters					
Code	Description	Contents	Predetermined area	Factory setting	Change
P8.00	Operation monitoring parameter item	For example: P8.00=2, that is, select the output voltage (d-02), then the default display item of the main monitoring interface is the current output voltage value.	0~26	0	○
P8.01	Shutdown monitoring parameter	For example: P8.01=3, that is, select the bus voltage (d-03), then the default display item of the main monitoring interface is the current bus voltage value.	0~26	1	○
P8.02	Motor speed display factor	It is used to correct the display error of the speed scale and has no effect on the actual speed.	0.01~99.99	1.00	○
P8.03	Parameter initialization	0: no operation	0~2	0	×
		The frequency inverter is in the normal parameter read and write status. Function code setting value. Whether it can be changed depends on the setting status of the user password and the working status of the frequency inverter.			
		1: Restore factory settings			
		All user parameters are restored to factory defaults by model.			
		2: Clear the fault record			
		Clear the contents of the fault record (d-19~d-24). This function code is automatically cleared to 0 after the operation is completed.			
P8.04	MF key setting	0: MF	0~3	0	×
		1: forward and reverse switching			
		2: Clear ▲/▼ key frequency setting			
		3: Reverse run (the RUN button defaults to forward)			

P9 group - manufacturer parameters					
Code	Description	Contents	Predetermined area	Factory setting	Change
P9.00	Manufacturer password	1~9999	1	****	◇

Group D - monitoring parameter group					
Function code	Name	Range	Minimum unit	Factory setting	Change
d-00	Output frequency (Hz)	0.0~999.9Hz	0.1Hz	0.0Hz	◆
d-01	Set frequency (Hz)	0.0~999.9Hz	0.1Hz	0.0Hz	◆
d-02	Output voltage (V)	0~999V	1V	0V	◆
d-03	Bus voltage (V)	0~999V	1V	0V	◆
d-04	Output current (A)	0.0~999.9A	0.1A	0.0A	◆
d-05	Motor speed (Krpm)	0~60000Krpm	1Krpm	varies by model	◆
d-06	Analog input AVI(V)	0.00~10.00V	0.01V	0.00V	◆
d-07	Analog input ACI (mA)	0.00~20.00mA	0.01mA	0.00mA	◆
d-08	Analog input AFM (V/mA)	0.00~10.00V/0.00~20.00mA	0.01V/0.01mA	0.00V/mA	◆
d-09	Reserved	-	-	0	◆
d-10	Pulse input frequency (KHz)	0.00~99.99KHz	0.01KHz	0.00KHz	◆
d-11	PID pressure feedback value	0.00~10.00V/0.00~99.99(MPa、Kg)	0.01V/(MPa、Kg)	0.00V/(MPa、Kg)	◆
d-12	Current count value	0~9999s	1s	0s	◆
d-13	Current timing value (s)	0~9999s	1s	0s	◆
d-14	Input terminal status (M1-M5)	0~1FH	1H	0H	◆
d-15	Output relay status (R)	0~1H	1H	0H	◆
d-16	Module temperature (°C)	0.0~132.3°C	0.1°C	0.0	◆
d-17	Software upgrade date (year)	2010~2026	1	2017	◆
d-18	Software upgrade date (month, day)	0~1231	1	0914	◆
d-19	Second fault code	0~19	1	0	◆
d-20	Last fault code	0~19	1	0	◆
d-21	Output frequency (Hz) at the latest fault	0.0~999.9Hz	0.1Hz	0.0Hz	◆
d-22	Output current at the most recent fault (A)	0.0~999.9A	0.1A	0.0V	◆
d-23	Bus voltage (V) at the most recent fault	0~999V	1V	0V	◆
d-24	Module temperature at the most recent fault (°C)	0.0~132.3°C	0.1°C	0.0°C	◆
d-25	Accumulated running time of frequency inverter (h)	0~9999h	1h	0h	◆

Function code	Name	Range	Minimum unit	Factory setting	Change
d-26	Frequency inverter status	0 to FFFFH	1H	0H	◆
		BIT0: Run/Stop			
		BIT1: Reverse / Forward			
		BIT2: Jog			
		BIT3: DC braking			
		BIT4: Reserved			
		BIT5: Overvoltage limit			
		BIT6: Constant speed down frequency			
		BIT7: Overcurrent limit			
		BIT8~9:00-zero speed/01-acceleration/10-deceleration/11-uniform speed			
		BIT10: Overload pre-alarm			
		BIT11: Reserved			
		BIT12~13 running command channel: 00-panel /01-terminal/10-reserved			
		BIT14~15 bus voltage status: 00-normal/01-low voltage protection/10-overpressure protection			

Group E - fault code					
Error code	Name	Possible cause of failure	Troubleshooting	Code	Error code
E0C1	Accelerate overcurrent during operation	Acceleration time is too short	Increase acceleration time	1	E0C1
		The frequency inverter power is too small	Use a frequency converter with a large power rating		
		Improper setting of V/F curve or torque boost	Adjust the V/F curve or torque boost		
E0C2	Over-current during deceleration	Deceleration time is too short	Increase deceleration time	2	E0C2
		The frequency inverter power is too small	Use a frequency converter with a large power rating		
E0C3	Overcurrent in constant speed operation	Low grid voltage	Check input power	3	E0C3
		Abrupt or abnormal load	Check load or reduce load change		
		The frequency inverter power is too small	Use a frequency converter with a large power rating		
EHU1	Accelerating overpressure during operation	Abnormal input voltage	Check input power	4	EHU1
		Restart the rotating motor	Set to start after DC braking		

Error code	Name	Possible cause of failure	Troubleshooting	Code	Error code
EHU2	Overpressure during deceleration operation	Deceleration time is too short	Increase deceleration time	5	EHU2
		Abnormal input voltage	Check input power		
EHU3	Overpressure during constant speed operation	Abnormal input voltage	Check input power	6	EHU3
ELU0	Undervoltage in operation	The input voltage is abnormal or the relay is not connected	Check the power supply voltage or seek service from the manufacturer	8	ELU0
ESC1	Power module failure	frequency inverter output short circuit or ground	Check motor wiring	9	ESC1
		frequency inverter transient overcurrent	See overcurrent countermeasures		
		The control board is abnormal or the interference is serious.	Seek service from manufacturers		
		Power device damage	Seek service from manufacturers		
E-OH	Heat sink overheating	Ambient temperature is too high	Reduce ambient temperature	10	E-OH
		Fan damage	Replace the fan		
		Air duct blockage	Ventilation		
EOL1	Frequency inverter overload	Improper setting of V/F curve or torque boost	Adjust V/F curve and torque boost	11	EOL1
		Grid voltage is too low	Check grid voltage		
		Acceleration time is too short	Increase acceleration time		
		Motor overload	Select a higher power frequency inverter		
EOL2	Motor overload	Improper setting of V/F curve or torque boost	Adjust V/F curve and torque boost	12	EOL2
		Grid voltage is too low	Check grid voltage		
		Motor stalled or the load is too large	Check load		
		Motor overload protection factor setting is incorrect	Correctly set the motor overload protection factor		
E-EF	External device failure	External device fault input terminal is closed	Disconnect the external device fault input terminal and clear the fault (note the cause of the check)	13	E-EF

Error code	Name	Possible cause of failure	Troubleshooting	Code	Error code
EPID	PID feedback disconnection	PID feedback line is loose	Check feedback connection	14	EPID
		The feedback amount is less than the disconnection detection value	Adjust the detection input threshold		
E485	RS485 communication failure	RS485 channel interference	Check whether the communication connection is shielded, whether the wiring is reasonable, and if necessary, consider connecting the filter capacitor.	15	E485
		Communication timeout	Retry		
ECCF	Current detection fault	Current sampling circuit failure	Seek service from manufacturers	16	ECCF
		Auxiliary power failure			
EEEP	EEPROM read and write error	EEPROM failure	Seek service from manufacturers	17	EEEP
EPAO	Burst failure	The feedback pressure is less than the low pressure detection threshold or greater than or equal to the high pressure detection threshold	Detect feedback connection or adjust detection high and low pressure threshold	18	EPAO
EPOF	Dual CPU communication failure	CPU communication failure	Seek service from manufacturers	19	EPOF

COMMUNICATION

The following data are all in hexadecimal.

1. RTU mode and format

When the controller communicates on Modbus in RTU mode, every 8 bits of information is divided into two 4-bit hexadecimal characters, the main advantage of this mode is the word it transmits at the same baud rate

Character density is higher than ASCII mode, and each message must be transmitted continuously.

(1) Format of each byte in RTU mode

Coding system: 8-bit binary, hexadecimal 0-9, A-F.

Data bit: 1 bit starting, 8 bits data (low bit first), 1 bit stopping, odd

The parity bit is optional. (Refer to RTU data frame as sequence diagram)

Error check area: Cyclic redundancy check (CRC).

(2) Frame bitmap of RTU data

With parity

start	1	2	3	4	5	6	7	8	par	stop
-------	---	---	---	---	---	---	---	---	-----	------

Without parity

start	1	2	3	4	5	6	7	8	stop
-------	---	---	---	---	---	---	---	---	------

2. Description of read and write function code

Function code	Function description
03	Read register
06	Write register

3. Parameter address description of communication

Function	Adress description	Data statement	R/W
Communication control command	2000H	0001H: Stop 0012H: Forward 0013H: Forward jog 0022H: Reverse 0023H: Reverse jog	W
Address of communication frequency setting	2001H	The communication set frequency range is -10000~10000 Note: The communication set frequency is the percentage relative to the maximum frequency and ranges from -100.00% to 100.00%.	W
Communication control command	2002H	0001H: External fault input 0002H: Fault reset	W
Read run / stop parameters Description	2102H	Set frequency (two decimal places)	R
	2103H	Output frequency (two decimal places)	R
	2104H	Output current (decimal bit)	R
	2105H	Bus voltage (decimal bit)	R
	2106H	Output voltage (decimal bit)	R
	210DH	Frequency converter temperature (decimal place)	R
	210EH	PID feedback value (two decimal places)	R
	210FH	PID setting value (two decimal places)	R
Fault code instructions	2101H	Bit0: sun Bit1: stop Bit2: jog Bit3: forward Bit4: reverse Bit5 ~ Bit7: Reserved Bit8: communication given Bit9: Analog signal input Bit10: Communication run command channel Bit11: Parameter locking	

		Bit12: running Bit13: with jog command Bit14 - Bit15: Reserved 00: normal 01: Module failure 02: Over voltage 03: Temperature failure 04: VFD overload 05: Motor overload 06: External failure 07 ~ 09: Reserved 10: overcurrent in Acceleration 11: Overcurrent in deceleration 12: overcurrent medium constant speed 13: keep 14: undervoltage	
--	--	---	--

4. 03 Read functional mode

Inquiry information frame format.

Address	01H
Function	03H
Starting data address	21H
	02H
Data(2Byte)	00H
	02H
CRC CHK Low	6FH
CRC CHK High	F7H

This section of data analysis:

01H----- VFD address

03H----- Read function code

2102H----Initial address

0002H----the number of read addresses, and 2102H and 2103H

F76FH -- 16 bit CRC code

Response information frame format:

Address	01H
Function	03H
Data Num*2	04H
Data 1 [2 byte]	17H
	70H
Data 2 [2 byte]	00H
	00H
CRC CHK Low	FEH
CRC CHK High	5CH

This section of data analysis:

- 01H----- VFD address
- 03H----- Read function code
- 04H----- Read term times the product of 2
- 1770H-----Read data at 2102H (set frequency)
- 0000H-----Read data at 2103H (output frequency)
- 5CFEH-----16 bit CRC code

5. 06H write function mode
 Inquiry information frame format

Address	01H
Function	06H
Starting data address	20H
	00H
Data (2 byte)	00H
	01H
CRC CHK Low	43H
CRC CHK High	CAH

This section of data analysis:

- 01H----- VFD address
- 06H----- Write function code
- 2000H-----Control command address
- 0001H-----Stop command
- 43CAH----- 16 bit CRC code

Response information frame format

Address	01H
Function	06H
Starting data address	20H
	00H
Number of Data(Byte)	00H
	01H
CRC CHK Low	43H
CRC CHK High	CAH

This section of data analysis: returns the same input data if set correctly.

FEEL FREE TO CONTACT

E: sales@jaaris.com

A: No.786/5, Samurdhi Mawatha, Heiyanthudawa, SRI LANKA.

W: www.jaaris.com

M: 0094767015546